

The Ojas is Esthetica's flat top medical treatment table — a clean, reliable surface built for general examination and massage treatments in clinical and medical spa environments. Electronic height adjustment via a Linak motor from Denmark delivers smooth, precise elevation from 530mm to 890mm, allowing clinicians to set their ideal working height at the touch of a button. A detachable external face cradle fits to either side of the table, adding flexibility for prone position treatments. Built on a powder-coated mild steel frame with a 50mm 40-density foam cushion and a robust lifting capacity of up to 360 kgs, the Ojas is engineered for the long-term demands of daily clinical use. Optional castor wheels and a walk-free switch extend its functionality further, making it equally at home in busy clinic and treatment room environments.

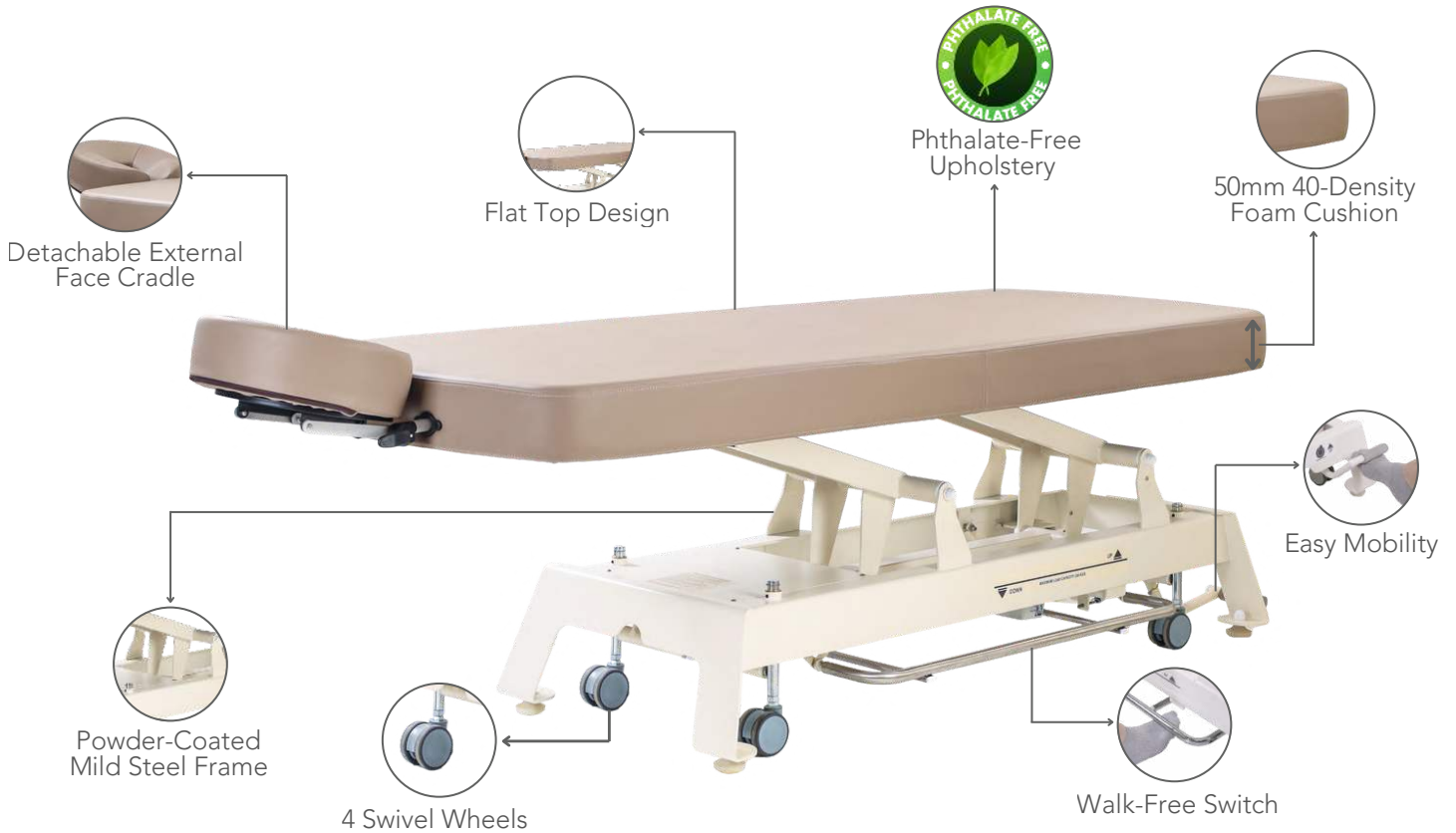

KEY FEATURES



DIFFERENCE BETWEEN PRO AND BASIC MODEL

PRO MODEL

- **Walk Free Switch**

The Pro Model comes with a hands-free foot control system for height adjustments. It enhances hygiene, efficiency, ergonomics and can be operated from both sides. IEC 60601-1 safety requirement and IEC 60601-1-2 EMC standard compliant.

- **Easy Mobility**

The Pro Models have an easy mobility feature, which allows effortless repositioning of the treatment table within clinical environments. With a press of a lever, the table is lifted onto four wheels for smooth movement. When mobility is no longer required, the table can be securely fixed back on the ground for stability during procedures.

BASIC MODEL

- **Foot Switch**

Basic Model only comes with a wired foot controller for height adjustment by pressing the + or – symbols on the foot switch, as shown in the image below.



UPHOLSTERY

Phthalate-Free Upholstery

Phthalate-Free Upholstery offers a safer, hospital-grade surface that resists stains, disinfectants, and abrasion, ensuring hygienic, durable, and eco-friendly performance across demanding clinical environments.



FEATURES

Face Cradle	Detachable and Adjustable
Height	Electronically Adjustable
Walk Free Switch	Enables you to operate the table from both sides
Castor Wheels	For easy mobility in the treatment room

TECHNICAL SPECIFICATIONS

Length	2240 mm / 88 in
Width	750 mm / 29.5 in
Minimum Height	530 mm / 20.8 in
Maximum Height	890 mm / 35 in

ELECTRICAL PARAMETERS

Power in (Mains Power Supply)	100-240 V, 50-60 HZ, 2A
IPX Rating	IPX4
Operating Temperature	5-40°C
Shock Protection:	Class I

BASE & FRAME

Frame Structure	Mild steel construction powder coated frame & ABS molded parts
Base	Powder coated metal frame
Safe Working Load	180 kgs

SAFETY STANDARDS

General safety for medical electrical equipment	IEC 60601-1
EMI/EMC	IEC 60601-2

UPHOLSTERY

Type	Phthalate-Free Upholstery
Thickness	1.01 mm
Tensile Strength	ISO 1421, 804 N/ 5 cm
Colour Options	Cream, Beige, Brown, Mouse Grey
Weight	732 g / sqmt
Abrasion	ISO 5470-2 = 2,00,000 cycles / min

WARRANTY

3 years on motors



TECHNICAL DRAWINGS

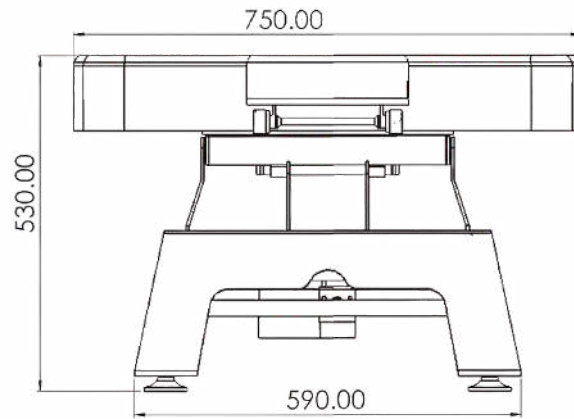

FRONT VIEW

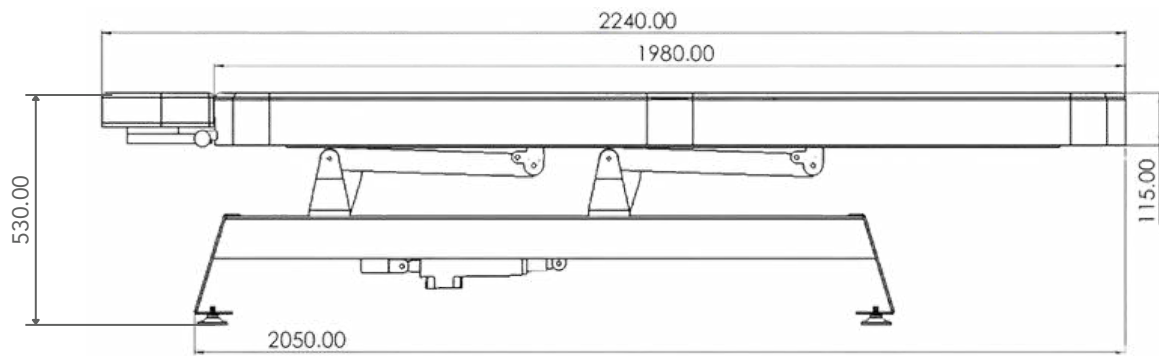

MINIMUM HEIGHT

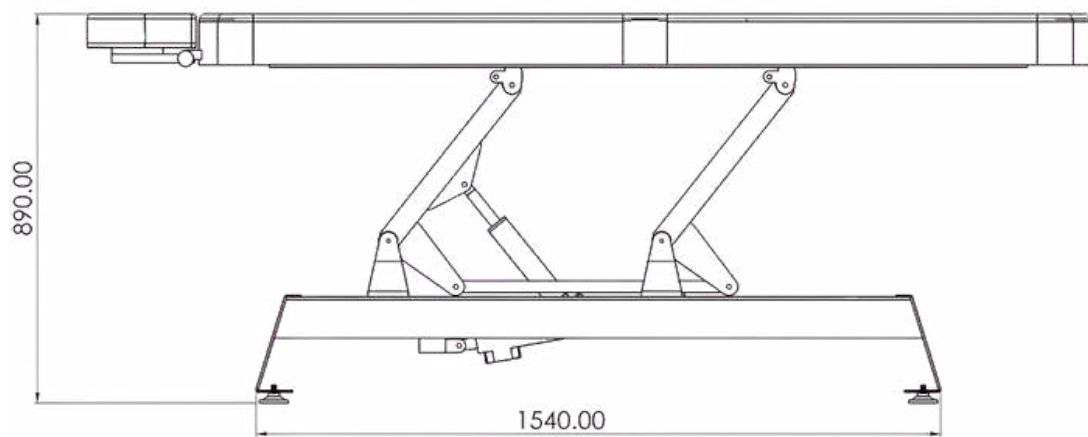

MAXIMUM HEIGHT

ALL DIMENSIONS ARE IN MM